

Underground Mining Methods and Applications

Hans Hamrin*

1.1 INTRODUCTION

Ore is an economic concept. It is defined as a concentration of minerals that can be exploited and turned into a saleable product to generate a financially acceptable profit under existing economic conditions. The definition of ore calls for afterthoughts. Ore does not properly exist until it has been labeled as such. To name a mineral prospect an ore body requires more information than needed to establish metal grades. Sufficient knowledge of the mineral deposit, mining technology, processing methods, and costs is needed for undertaking a feasibility study and proving the prospect worthy of being developed into a mine.

The expression "existing economic conditions" deserves an explanation. "Run-of-mine" ore is a mix of valuable minerals and worthless rock in which each ingredient is priced separately. Run-of-mine ore is treated in the dressing plant and processed into different concentrates. Where the ore contains more than one metal of value, separate concentrates of, for example, copper, zinc, and lead are produced. The value of in situ ore can be calculated by applying market prices to metal content and deducting costs for treatment and transportation of concentrates and smelter fees. The balance must cover direct mining costs and leave a margin for the mine operator.

Metal prices are set on international metal market exchanges in London and New York and fluctuate from day to day, depending on the supply-and-demand situation. An oversupply builds stocks of surplus metal, which is reflected in a drop in the market price. The profit margin for a mine decreases as the values of its products drop. As costs for processing, transport, smelting, and refining remain constant, the mine must adjust to a reduced income. The mine operating on a narrow margin must be prepared to survive periods of depressed metal prices.

One tactic to deal with such a situation is to adjust the boundaries of the area being mined and draw these boundaries at a higher cut-off grade. This will increase the value of the run-of-mine product, and the mine will maintain its profit. Another way is to increase the efficiency of mine production. Modifying the mining method and introducing new, more powerful machines are actions that should raise the efficiency of work procedures. The mine must remain a profit generator, which is not a simple task in an environment of increasing labor costs and demands for better living.

This chapter describes and explains methods for the underground mining of mineral deposits. The descriptions are generalized and focus on typical applications. Examples chosen illustrate types of mining practices as of 1999. However, every mineral deposit, with its geology, grade, shape, and volume, is unique. As methods are described here, please bear in mind that rock is variable, miners have ideas, and the world of mines will always display special features.

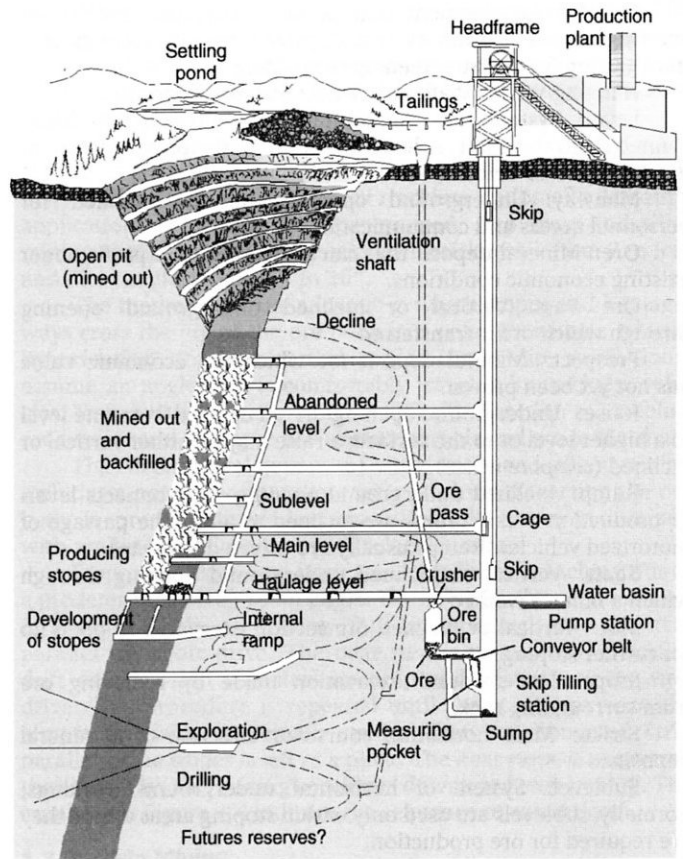

FIGURE 1.1 The underground mine—basic infrastructure

1.2 DEFINITION OF TERMS

To better understand the material presented herein, some of the more common mining terms are defined in the following paragraphs. Figure 1.1 further clarifies some of the terms.

Adit: Horizontal or nearly horizontal entrance to a mine.

Back: Roof or overhead surface of an underground excavation.

Chute: Loading arrangement that utilizes gravity to move material from a higher level to a lower level.

Cone: Funnel-shaped excavation located at the top of a raise used to collect rock from the area above.

* Retired, Atlas Copco, Stockholm, Sweden.

Crosscut: Horizontal or nearly horizontal underground opening driven to intersect an ore body.

Dip: Angle at which an ore deposit is inclined from the horizontal.

Drawpoint: Place where ore can be loaded and removed. A drawpoint is located beneath the stoping area, and gravity flow transfers the ore to the loading place.

Drift: Horizontal or nearly horizontal underground opening.

Finger Raise: Typically, a system of several raises that branch together to the same delivery point. Used for transferring ore.

Footwall: Wall or rock under the ore deposit.

Grizzly: Arrangement that prevents oversized rock from entering an ore transfer system. A grizzly usually consists of a steel grating for coarse screening or scalping.

Hanging Wall: Wall or rock above an ore deposit.

Level: System of horizontal underground workings connected to the shaft. A level forms the basis for excavation of the ore above or below.

Manway: Underground opening that is intended for personnel access and communication.

Ore: Mineral deposit that can be worked at a profit under existing economic conditions.

Ore Pass: Vertical or inclined underground opening through which ore is transferred.

Prospect: Mineral deposit for which the economic value has not yet been proven.

Raise: Underground opening driven upward from one level to a higher level or to the surface; a raise may be either vertical or inclined (*compare winze*).

Ramp: Inclined underground opening that connects levels or production areas; ramps are inclined to allow the passage of motorized vehicles. Ramps usually are driven downward.

Shaft: Vertical or inclined underground opening through which a mine is worked.

Slot: Vertical or inclined ore section excavated to open up for further stoping.

Stope: Underground excavation made by removing ore from surrounding rock.

Strike: Main horizontal course or direction of a mineral deposit.

Sublevel: System of horizontal underground workings; normally, sublevels are used only within stoping areas where they are required for ore production.

Wall Rock: Wall in which an ore deposit is enclosed.

Waste: Barren rock or rock of too low a grade to be mined economically.

Winze: Vertical or inclined underground opening driven downward from one level to another level or from the surface to a level (*compare raise*).

1.3 MINING METHODS

1.3.1 Introduction

Once an ore body has been probed and outlined and sufficient information has been collected to warrant further analysis, the important process of selecting the most appropriate method or methods of mining can begin. At this stage, the selection is preliminary, serving only as the basis for a project layout and feasibility study. Later it may be found necessary to revise details, but the basic principles for ore extraction should remain a part of the final layout.

With respect to the basic principles employed, relatively few mining methods are used today. Because of the uniqueness of each ore deposit, variations on each of these methods are nearly limitless. It is impossible to include even the major variations in

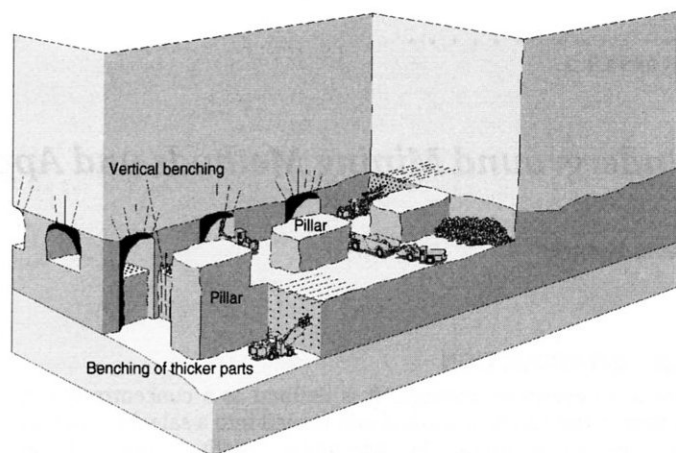

FIGURE 1.2 Classic room-and-pillar mining

this chapter; the goal of this chapter is to summarize briefly the characteristics of the major mining methods.

1.3.2 Room-and-Pillar Mining

Room-and-pillar mining is designed for flat-bedded deposits of limited thickness, such as copper shale, coal, salt and potash, limestone, and dolomite. This method is used to recover resources in open stopes. The method leaves pillars to support the hanging wall; to recover the maximum amount of ore, miners aim to leave the smallest possible pillars. The roof must remain intact, and rock bolts are often installed to reinforce rock strata. Rooms and pillars are normally arranged in regular patterns. Pillars can be designed with circular or square cross sections or shaped as elongated walls separating the rooms. Minerals contained in pillars are nonrecoverable and therefore are not included in the ore reserves of the mine. Differing geological conditions give rise to variations in room-and-pillar mining. Three typical variations are described in the following text.

Classic room-and-pillar mining (Figure 1.2) applies to flat deposits having moderate-to-thick beds and to inclined deposits with thicker beds. Mining the ore body creates large open stopes where trackless machines can travel on the flat floor. Ore bodies with large vertical heights are mined in horizontal slices starting at the top and benching down in steps.

Post room-and-pillar mining (Figure 1.3) applies to inclined ore bodies with dip angles from 20° to 55°. These mines have large vertical heights where the mined-out space is backfilled. The fill keeps the rock mass stable and serves as a work platform while the next ore slice is mined.

Step room-and-pillar mining (Figure 1.4) is an adaptation of trackless mining to ore bodies where dip is too steep for rubber-tired vehicles. A special “angle” orientation of haulage drifts and stopes related to dip creates work areas with level floors. This allows trackless equipment to be used in drilling and mucking. Mining advances downward along the step room angle.

Classic Room-and-Pillar Mining. In classic room-and-pillar mining, only a minimum of development work is required to prepare a flat-bedded deposit for mining. Roadways for ore transport and communication are established inside production stopes. Excavation of roadways can be combined with ore production, and mined-out stopes can serve as transport routes.

Ore production involves the same drill-blast techniques as in normal drifting where drift dimensions equal the width and height of the stope. Where geological conditions are favorable, stopes can be large, and big drill jumbos can be used for mechanized drilling.

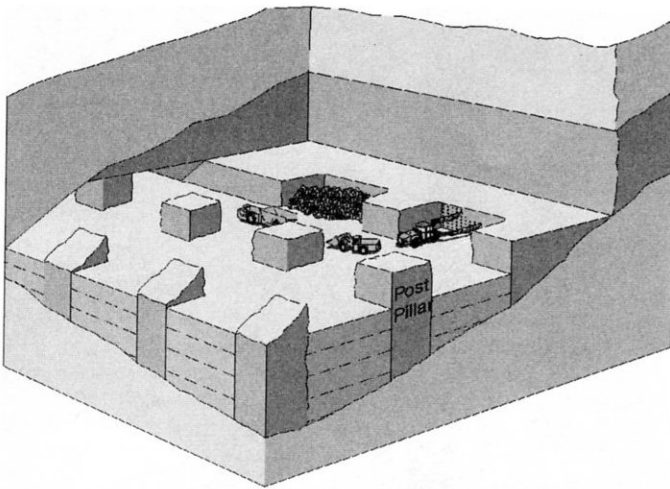

FIGURE 1.3 Post room-and-pillar mining

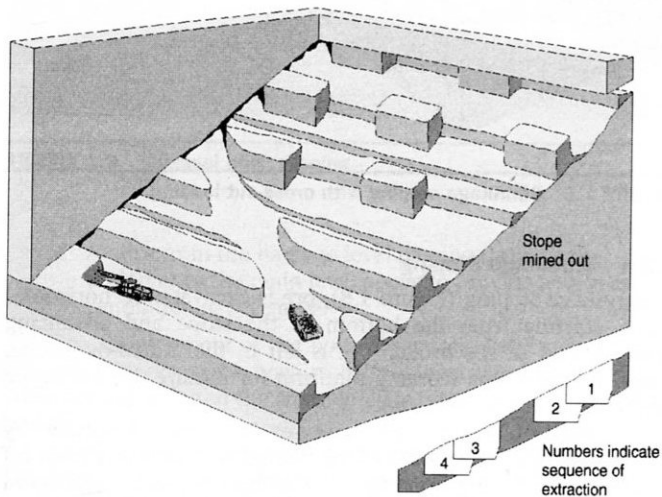

FIGURE 1.4 Step-room mining of inclined orebody

Deposits with large vertical heights are mined in slices. Mining starts at the top below the hanging wall. At this stage, rock bolts are installed for roof control with the back at a convenient height. Sections below are recovered in one or more steps by benching. Standard crawler rigs are used for drilling vertical holes and for conventional bench blasting. Horizontal drilling and “flat” benching are more practical alternatives because the same drill jumbo can be used for both topheading and drilling flat bench holds.

The blasted ore is loaded at the muckpile with diesel-driven front-end loaders. Different transport systems are used, depending on stope height and transport distance. Where the opening is high enough, the common dump truck provides economical transport from stopes to collection points. In thin ore bodies, specially built low mine trucks are available from manufacturers. Stopes with very little headroom can be cleaned by load-haul-dump (LHD) machines, and muck can be transferred onto trucks parked in special loading bays for transport over longer distances.

Mobile mechanized equipment is ideal in flat or slightly inclined ore bodies. In the room-and-pillar layout, several production areas can be established. Communications are straightforward and simple. These factors set the stage for the high utilization of both men and machines in an efficient ore recovery system.

Post Room-and-Pillar Mining. Post room-and-pillar mining (or “post-pillar” mining) is a combination of room-and-pillar and cut-and-fill stoping. With this method, ore is recovered in horizontal slices starting from the bottom and advancing upward. Pillars are left inside the stope to support the roof. Mined-out stopes are hydraulically backfilled with tailings, and the next slice is mined by machines working from the fill surface. Pillars continue through several layers of fill. Sandfill provides the possibility of modifying the stope layout and adapting the post-pillar method to variations in rock conditions and ore boundaries. Both backfill and sandfill increase the support capability of the pillar, permitting a higher rate of ore recovery than does classic room-and-pillar mining.

Post-pillar mining combines the advantages of cut-and-fill mining—that is, allowing work on flat, smooth floors—with the spacious stopes offered by room-and-pillar mining. Easy access to multiple production points favors the use of efficient mechanized equipment.

Step Room-and-Pillar Mining. Step room-and-pillar mining is a variation in which the footwall of an inclined ore body is adapted for efficient use of trackless equipment. Although applications cannot be fully generalized, step room-and-pillar mining applies to tabular deposits with thicknesses from 2 to 5 m and dips ranging from 15° to 30°.

The method features a layout in which stopes and haulage-ways cross the dip of the ore body in a polar coordinate system. By orienting stopes at certain angles across dip, stope floors assume an angle that is comfortably traveled by trackless vehicles. Transport routes cross in the opposite direction to establish roadway access to stopes and to transport blasted ore to the shaft.

The main development of step room-and-pillar mining includes a network of parallel transport drifts traversing the ore body in predetermined directions. Drift floors are maintained with grades that allow the use of selected trucks.

Stopes are excavated from transport drifts branching out at a predetermined step-room angle. The stope is advanced forward in a mode similar to drifting until breakthrough into the next parallel transport drive. The next step is to excavate a similar drift or side slash one step down and adjacent to the first drive. This procedure is repeated until the roof span becomes almost too wide to remain stable. Then an elongated strip parallel to the stopes is left as a pillar. The next stope is excavated the same way, and mining continues downward step by step. The numbers in Figure 1.4 indicate the sequence of extraction.

1.3.3 Vein Mining

In vein mines (Figures 1.5, 1.6, and 1.7), the dimensions of mineral deposits are highly variable. An ore body can be anything from a large, massive formation several square kilometers in surface area to a 0.5-m-wide quartz vein containing some 20 g/tonne of gold. Miners aim to recover the mineral’s value, but prefer to leave waste rock in the hanging wall and the footwall intact. In the thicker deposits, a machine operates within the ore body walls without problems. When the mineralized zone narrows to a few meters, machines may be too wide to fit inside the ore boundaries. To excavate rock only to permit the machine to fit produces waste, which dilutes the ore. The alternative is to use manual labor to recover high-grade ore. However, labor is costly, and manual mining techniques are inefficient. Also, it is difficult to find people who accept working with hand-held rock drills and using muscle power.

Today, a selection of standard slim-sized machines is available, allowing mechanized mining in 2-m-wide drifts. These slim-sized machines include the face jumbo for narrow drifts matched with a longhole rig of the same size. The small drifter jumbo and longhole rig complemented with an LHD with a 2-m³ bucket provides everything needed for the mechanized mining of a 2-m-wide vein.

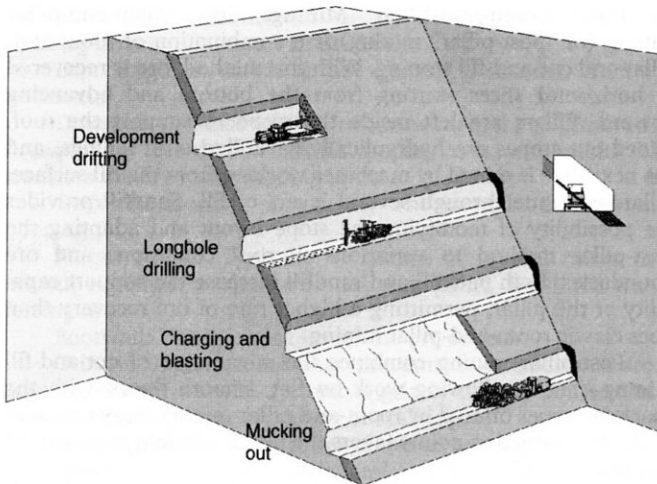

FIGURE 1.5 Mining a narrow vein with steep dip

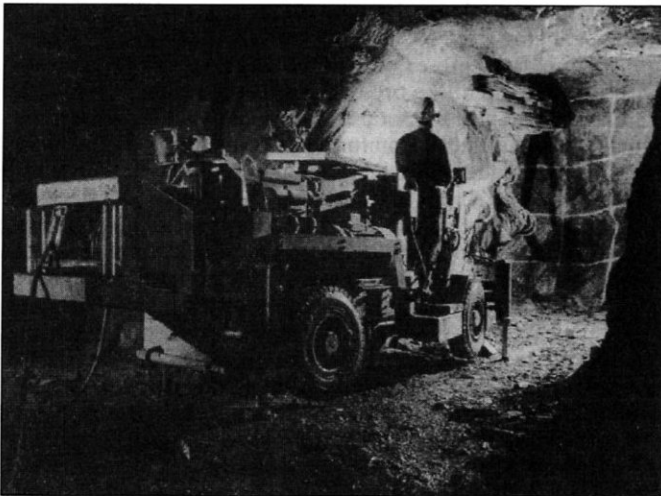

FIGURE 1.6 Small size drill jumbo, Dome mine, Canada



FIGURE 1.7 Mini-rig for longhole drilling, Stillwater platinum mine, Montana, USA

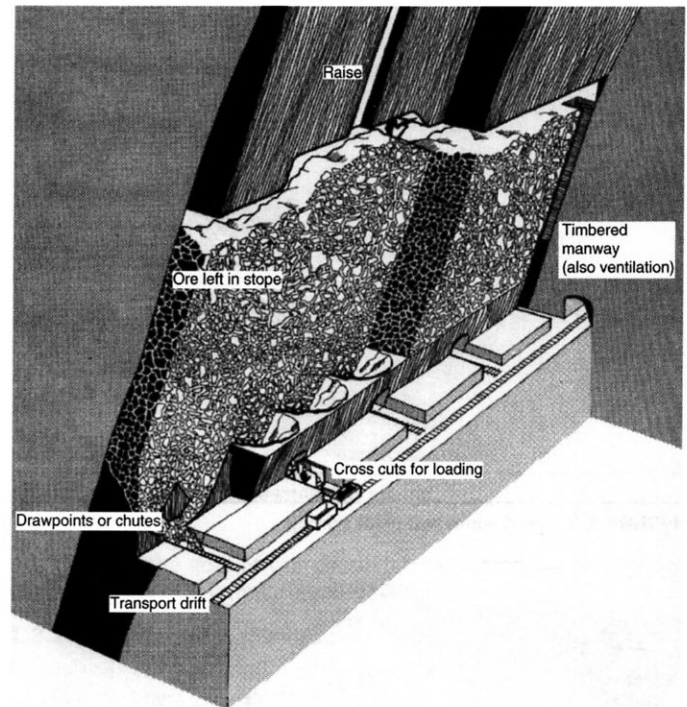

FIGURE 1.8 Shrinkage stoping with cross-cut loading

1.3.4 Shrinkage Stoping

In shrinkage stoping (Figure 1.8), ore is excavated in horizontal slices, starting from the bottom of the stope and advancing upward. Part of the broken ore is left in the mined-out stope, where it serves as a working platform for mining the ore above and to support the stope walls.

Through blasting, rock increases its occupied volume by about 50%. Therefore, 40% of the blasted ore must be drawn off continuously during mining to maintain suitable headroom between the back and the top of the blasted ore. When the stope has advanced to the upper border of the planned stope, it is discontinued, and the remaining 60% of the ore can be recovered.

Smaller ore bodies can be mined with a single stope, whereas larger ore bodies are divided into separate stopes with intermediate pillars to stabilize the hanging wall. The pillars can generally be recovered upon completion of regular mining. Shrinkage stoping can be used in ore bodies with

- Steep dips (the dip must exceed the angle of repose),
- Firm ore,
- Comparatively stable hanging wall and footwall,
- Regular ore boundaries,
- Ore that is not affected by storage in the stope (certain sulfide ores tend to oxidize and decompose when exposed to the atmosphere).

The development for shrinkage stoping consists of

- A haulage drift along the bottom of the stope,
- Crosscuts into the ore underneath the stope,
- Finger raises and cones from the crosscuts to the undercut,
- An undercut or complete bottom slice of the stope 5 to 10 m above the haulage drift, and

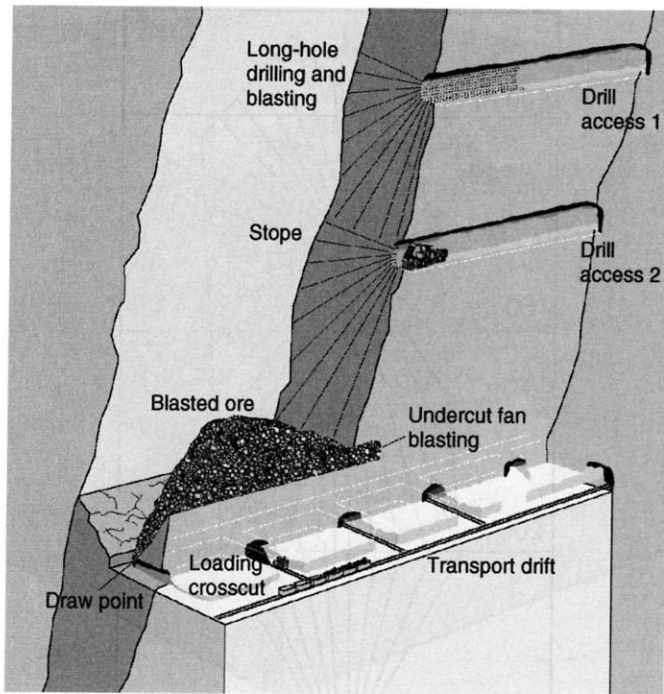

FIGURE 1.9 Sublevel open stoping

- A raise from the haulage level passing through the undercut to the main level above to provide access and ventilation to the stope.

The development of the bottom section of the stope can be simplified in the same way as for sublevel stoping—the finger raises are deleted, and the cross-cuts are developed for drawpoint loading.

Drilling and blasting are carried out as overhead stoping. The rough pile of ore in the stope prevents the use of mechanized equipment. Standard practice is to use air-leg rock drills and stoper drillers.

The traditional ore handling system in shrinkage stoping entails direct dumping of ore into rail cars from chutes below the finger raises. Shovel loaders are more effective in conjunction with a drawpoint loading system.

Shrinkage stoping was a common and important method in the days when few machines were employed in underground mining. Its advantage is the fact that the ore could be dumped directly into cars through the chutes, eliminating hand-loading. This is of little importance today, and the drawbacks—that is, the method is labor intensive, working conditions are difficult and dangerous, productivity is limited, and the bulk of the ore remains stored in the stope for a long period of time—have resulted in the replacement of shrinkage stoping by other methods. Sublevel stoping, vertical retreat stoping, sublevel caving, and cut-and-fill mining are methods that usually can be applied under similar conditions.

Shrinkage stoping remains, however, as one of the methods that can be practiced with a minimum of investment in machinery and yet is still not entirely dependent on manual capacity.

1.3.5 Sublevel Open Stoping

In sublevel open stoping (Figures 1.9 and 1.10), ore is recovered in open stopes normally backfilled after being mined. Stopes are often large, particularly in the vertical direction. The ore body is divided into separate stopes. Between stopes, ore sections are set aside for pillars to support the hanging wall. Pillars are normally shaped as vertical beams across the ore body. Horizontal sections

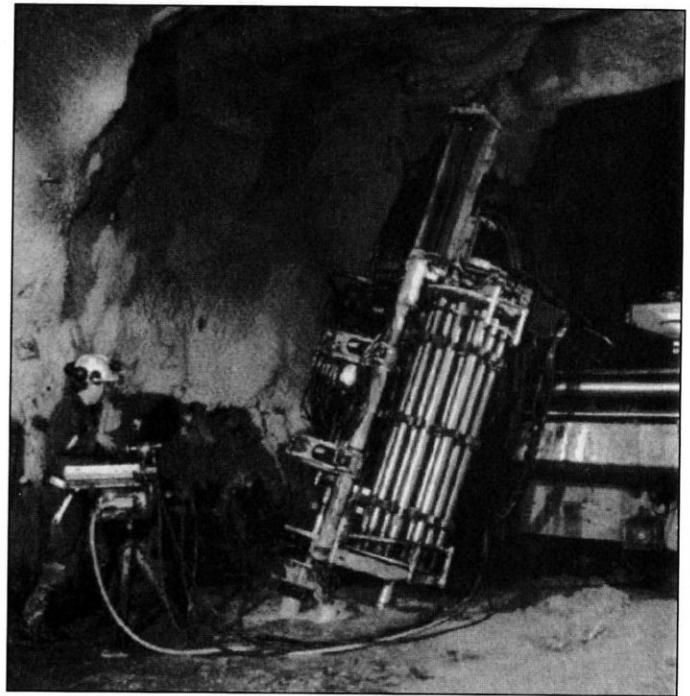

FIGURE 1.10 Longhole rig with slide positioning, remote control, and tube carousel, Williams gold, Canada

of ore, known as crown pillars, are also left to support mine workings above the producing stopes.

Enlarging stope dimensions influences mining efficiency. Miners therefore aim for the largest possible stopes. The stability of the rock mass is a limiting factor to be considered when selecting the sizes of stopes and pillars. Sublevel stoping is used for mining mineral deposits with following characteristics:

- Steep dip—the inclination of the footwall must exceed the angle of repose,
- Stable rock in both the hanging wall and the footwall,
- Competent ore and host rock,
- Regular ore boundaries.

Sublevel drifts for longhole drilling are prepared inside the ore body between main levels. These are strategically located since these are the points from which the longhole rig drills the blast pattern. The drill pattern specifies where blastholes are to be collared and the depth and angle of each hole, all of which must be set with great precision to achieve a successful blast.

Drawpoints are excavated below the stope bottom for safe mucking with LHDs, which may be combined with trucks or rail cars for longer transport. Different layouts for undercut drawpoints are used. The trough-shaped stope bottom is typically accessed through loading drifts at regular spacings.

Developing the set of drifts and drawpoints underneath the stope is an extensive and costly procedure. A simpler layout is gaining in popularity as an alternative to the conventional drawpoint-and-muck-out system. Here, the loading level is integrated with the undercut. Mucking out is done directly on the stope bottom inside the open stope. The LHD works inside the open stope and, for safety reasons, is operated by radio control by an operator based inside the access drift.

Sublevel stoping requires a regular shape of stopes and ore boundaries. Inside the drill pattern, everything qualifies as ore. In larger ore bodies, the area between the hanging wall and the footwall is divided into modules along strike and mined as primary and secondary stopes.

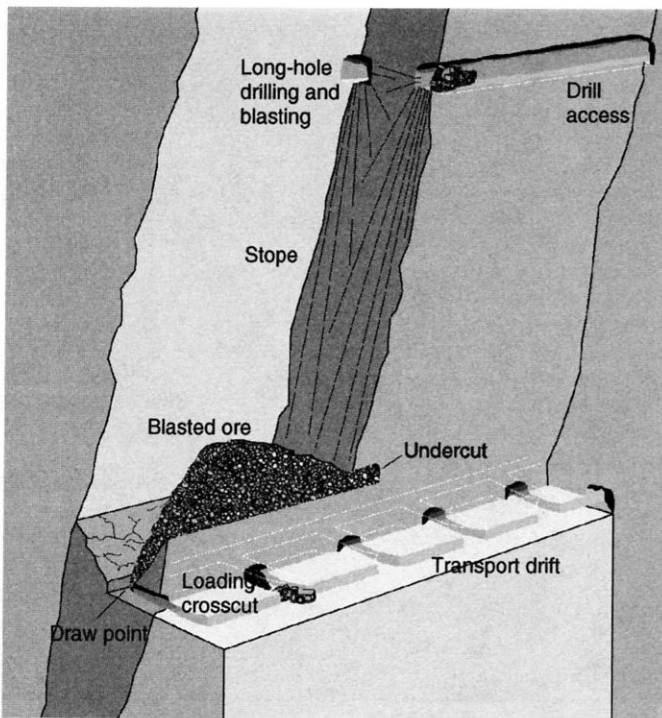

FIGURE 1.11 Bighole open stoping

1.3.6 Bighole Stoping

Bighole stoping (Figures 1.11–1.13) is a scaled-up variant of sublevel open stoping in which longer blastholes with larger diameters (140 to 165 mm) are used. The holes are normally drilled using the in-the-hole (ITH) technique. Hole depths may reach 100 m, which is double the length that can be drilled with tophammer rigs. Blast patterns are similar to those used in sublevel open stoping. The 140-mm-diameter blasthole breaks a rock slice 4 m thick with a 6-m toe spacing.

The advantage of bighole stoping as compared to sublevel stoping is the scale factor. The ITH-drilled holes are straight, and drilling accuracy can be exploited. For instance, vertical spacings between sublevels can be extended from 40 m with sublevel open stoping to 60 m with bighole stoping. Risks of damage to rock structures is a factor to be considered when bighole stoping is used.

1.3.7 Vertical Crater Retreat

Vertical crater retreat (VCR) mining (Figures 1.14, 1.15, and 1.16) is a method originally developed by the Canadian mining company INCO. Today, VCR is an established mining method used by mines all over the world that have competent, steeply dipping ore and host rock. VCR is based on the crater blasting technique in which powerful explosive charges are placed in large-diameter holes and fired. Part of the blasted ore remains in the stope over the production cycle, serving as temporary support for the stope walls.

The sequence of development of VCR stopes is

- A haulage drift is excavated along the ore body at the drawpoint level,
- A drawpoint loading arrangement is created underneath the stope,
- The stope is undercut,
- An overcut access is excavated for drilling and charging.

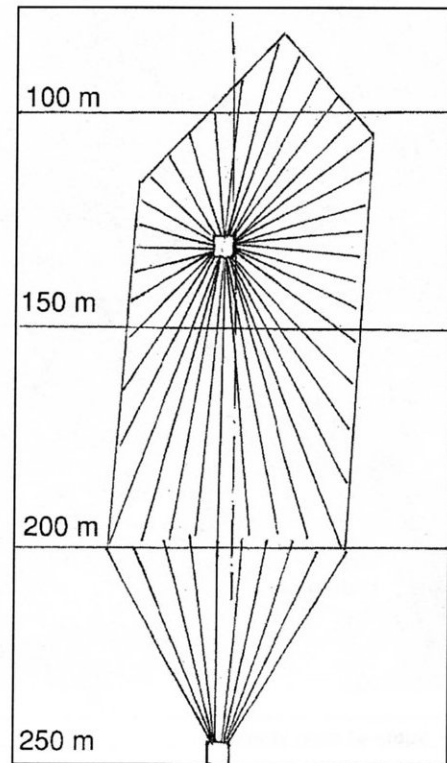

FIGURE 1.12 Bighole sample pattern, Mount Charlotte, Australia

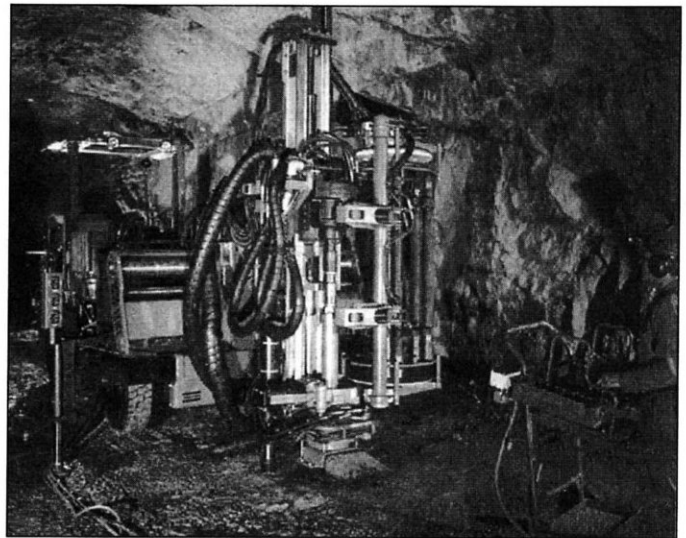

FIGURE 1.13 Bighole drill rig with automatic controls and tube carousel for 50 m long holes, Mount Charlotte, Australia

The ore in a stope block is drilled with ITH drill rigs positioned in the overcut. Holes are drilled downward until they break through into the undercut. Vertical holes are preferred wherever possible. Hole diameters vary from 140 to 165 mm, although holes 205 mm in diameter have been tried in a few mines. For 165-mm-diameter holes, a hole pattern of 4 by 4 m is typical.

Holes are charged from the overcut using powerful charges contained in a short section of blast hole. These crater charges

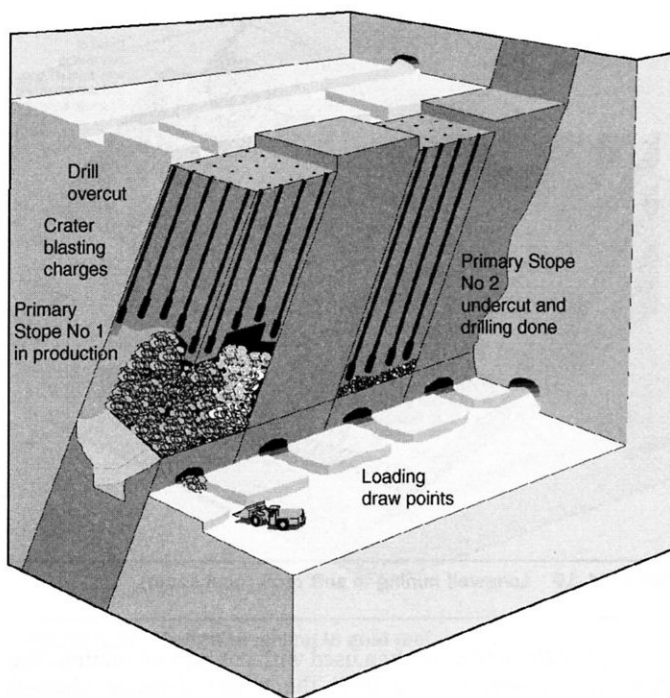

FIGURE 1.14 VCR mining, primary stopes

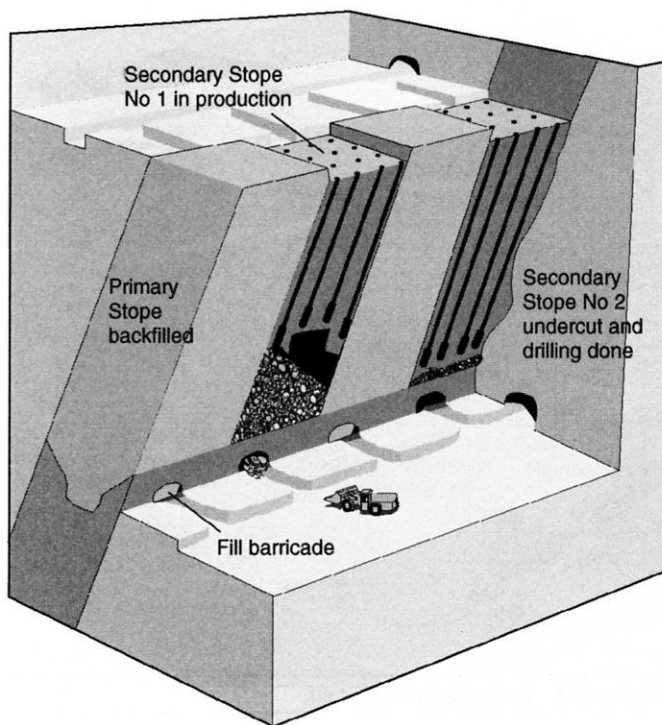

FIGURE 1.16 VCR mining, recovery of secondary stopes



FIGURE 1.15 ITH drilling, 165 mm blast holes, INCO, Canada

are placed a specified distance above the free surface. Holes are grouped so that charges will be at the same elevation and depth. First, the hole depth is measured. Then the hole is blocked at the proper height. Explosive charges are lowered, and the hole is stemmed with sand and water placed on top of the charge. Adjacent explosive charges aid in breaking the rock, normally loosening a 3-m slice of ore that falls into the void below. Charging

requires a trained crew for successful blast results, and records are necessary to keep track of the blasting progress in each hole. The ore is mucked from stopes through the undercut using remote-controlled LHDs or recovered by a drawpoint system underneath the stope as in sublevel stoping. The stopes may or may not be backfilled.

VCR mining is applicable in conditions similar to those in which sublevel open stoping is used. VCR is technically simpler with ITH drilling compared to tophammer drilling. ITH holes are straight, and hole deviations are minimal. The charging of the blastholes is complex, and techniques must be mastered by the charging team. The powerful VCR charges involve higher risks for damaging the surrounding rock than sublevel open stoping.

1.3.8 Cut-and-Fill Stoping

Cut-and-fill mining (Figures 1.17 and 1.18) removes ore in horizontal slices, starting from the bottom undercut and advancing upward. Ore is drilled and blasted, and muck is loaded and removed from the stope. When the stope has been mined out, voids are backfilled with hydraulic sand tailings or waste rock. The fill serves both to support the stope walls and provide a working platform for equipment when the next slice is mined.

Cut-and-fill mining is used in steeply dipping ore bodies in strata having good-to-moderate stability and comparatively high-grade ore. It provides better selectivity than the alternative sublevel stoping and VCR mining techniques. Hence, cut-and-fill is preferred for ore bodies having an irregular shape and scattered mineralization. Cut-and-fill allows selective mining, separate recovery of high-grade sections, and the leaving of low-grade rock behind in stopes.

The development for cut-and-fill mining includes

- A haulage drive along the footwall of the ore body at the main level,
- Undercutting the stope area with drains for water,

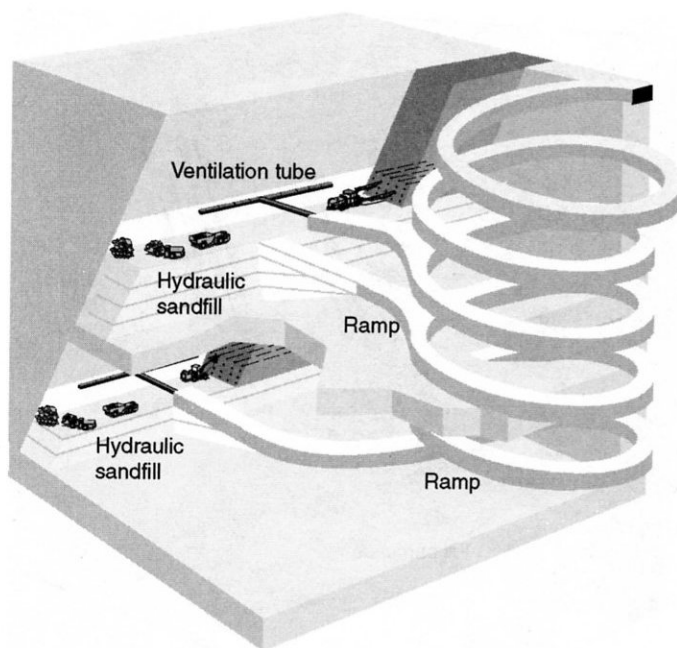

FIGURE 1.17 Mining with cut and fill

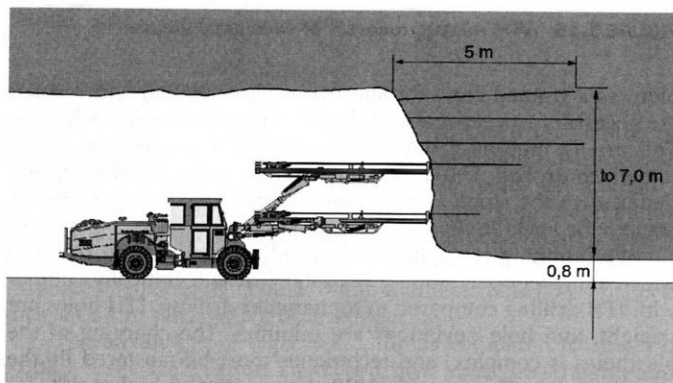

FIGURE 1.18 Face drilling in cut-and-fill stope

- A spiral ramp in the footwall with access drive to the undercut,
- A raise connecting to levels above for ventilation and filling material.

Modern cut-and-fill mines drill the stope face with a jumbo. The face appears to be a wall across the stope with an open slot at the bottom above the fill. The face is drilled with breasting holes, charged, and blasted. The slot underneath provides space into which the blasted rock can expand.

The drill pattern can be modified before each round to follow variations in ore boundaries. Sections with low-grade ore are left in place or separated while mucking out. Mining can be diverted from the planned stope boundaries to recover pockets of minerals in the host rock.

A smooth fill surface and controlled fragmentation are ideal for LHDs. Trimming distances inside the stope to the ore pass are convenient for LHD cycles. Ore passes made from steel segments welded to form a large tube can be positioned inside the stope, by-passing layers of sandfill. The ore pass can also consist of a raise excavated in rock close to the stope-ramp access.

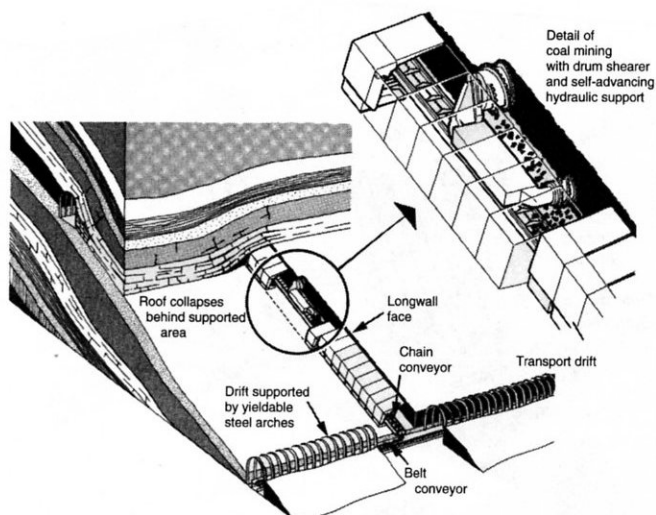

FIGURE 1.19 Longwall mining in soft rock (coal seam)

Hydraulic sandfill is often used with cut-and-fill mining. The fill—deslimed sand tailings from the mine's dressing plant—is mixed with water to 60% to 70% solids and distributed to stopes via a network of pipes. Before filling, stopes are prepared by barricading entries, and drainage tubes are laid out on the floor. The sand fills the stope to almost its full height. As a harder fill is required on the surface, cement is added in the last pour. When the water has drained, the fill surface is smooth and compact. It forms a good base for mobile machines while mining the next slice of ore.

Cut-and-fill mining is a versatile method and preferred by mines that require the capability of mining selected ore pockets and adaptability to variations in the rock mass.

1.3.9 Longwall Mining

Longwall mining applies to thin-bedded deposits of uniform thickness and large horizontal extent. Typical deposits are represented by coal seams, potash layers, or conglomerate reefs mined by the South African gold mining companies. Longwall mining applies to both hard and soft rock as the working area along the mining face can be artificially supported where the hanging wall tends to collapse.

The longwall mining method extracts ore along a straight front having a large longitudinal extension. The stoping area close to the face is kept open to provide space for personnel and mining equipment. The hanging wall may be allowed to subside at some distance behind the working face.

Development of longwall mines involves the excavation of a network of haulage drifts for access to production areas and transport of ore to shaft stations. As the mineralized zone extends over a large area, haulage drifts are accompanied with parallel excavations to ventilate mine workings. Haulage drifts are usually arranged in regular patterns and excavated in the deposit itself. The distance between two adjacent haulage drifts determines the length of the longwall face.

Longwall mining (Figure 1.19) is a common method for extracting coal, trona, and potash from seams of various thickness. It can be mechanized almost to perfection. The soft material does not require drilling and blasting, but can be cut loose mechanically. Special machines shaped as cutting plows or rotating drums with cutters run back and forth along the faces, each time cutting a fresh slice of the seam. The coal or mineral falls onto a chain conveyor that carries the mineral to the haulage

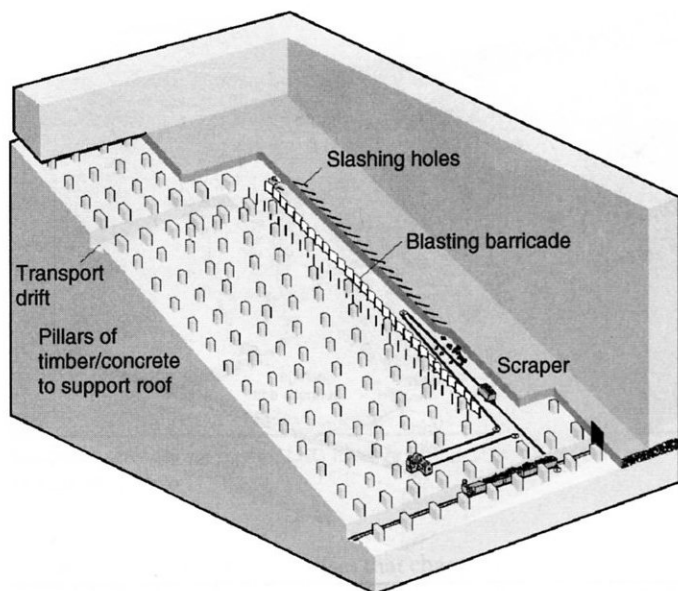

FIGURE 1.20 Longwall mining in gold reef



FIGURE 1.21 Drilling the reef with hand-held rock drill, East Rand Properties, South Africa

drift, from where it is transported for hoisting out of the mine. Conveyor belts are frequently used to transport material, as belts are adaptable to the almost continuous flow of material from the production areas. The roof along the longwall face is supported and the working area completely protected by a system of hydraulically operated props. The supports move forward as mining advances, and the roof behind can be allowed to collapse.

Longwall mining is also used for mining thin, reef-type deposits. The gold reef conglomerates are very hard and difficult to mine. South African gold mines have developed their own techniques based on manpower and the use of hand-held pneumatic rock drills. Figures 1.20 and 1.21 show mining of a reef approximately 1 m thick. The width of the mineralized section might be even less, but there must be space for miners crawling on their knees. Pillars of timber and concrete are installed to support the roof in very deep mines.

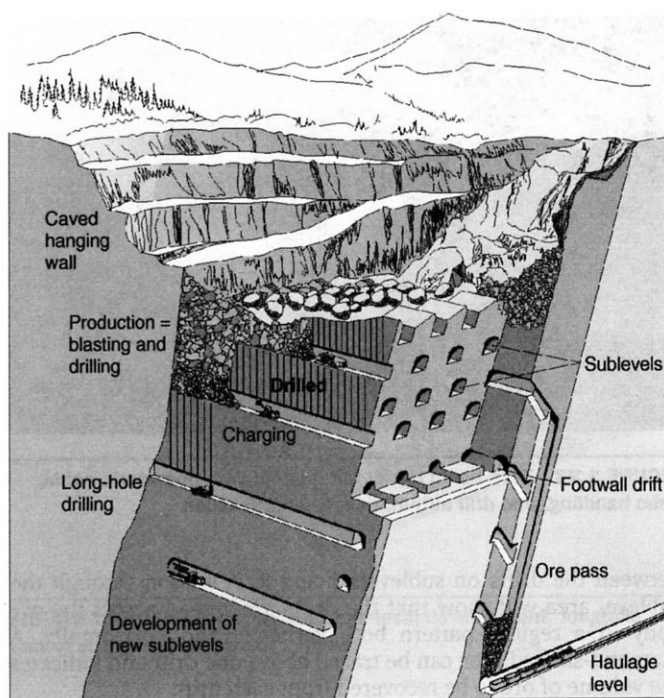

FIGURE 1.22 Mining by sublevel caving

1.3.10 Sublevel Caving

In sublevel caving, the ore is extracted via sublevels developed in the ore body at regular intervals. Each sublevel features a systematic layout with parallel drifts along or across the ore body. In a wide ore body, the sublevel drifts start from the footwall drift and are driven until they reach the hanging wall. This is referred to as transverse sublevel caving (Figure 1.22). In ore bodies of lesser width, longitudinal sublevel caving is used. In this variant, drifts branch off in both directions from a center crosscut.

Sublevel caving is used in large, steeply dipping ore bodies. The rock mass must be stable enough to allow the sublevel drifts to remain open with just occasional rock bolting. The hanging wall should fracture and collapse to follow the cave, and the ground on top of the ore body must be permitted to subside.

Caving requires a rock mass where both the ore body and the host rock fracture under controlled conditions. As mining removes rock and the mined-out area is not backfilled, the hanging wall keeps caving into the voids. Continued mining results in subsidence of the surface, and sinkholes may appear. Continuous caving is important to avoid creation of cavities inside the rock where a sudden collapse could be harmful to mine installations.

The amount of development needed to institute sublevel caving is extensive as compared to other mining methods. However, development primarily involves drifting to prepare sublevels. Drifting is a simple and routine job for a mechanized mine. Development of sublevels is done efficiently in an environment where there are multiple faces on one sublevel available to drill rigs and loaders.

A ramp is needed to connect different sublevels and communicate with the main transport routes. Ore passes are also required at strategic locations along the sublevels to allow LHDs to dump ore to be collected and transported to the haulage level below.

A drawing showing sublevel drifts is almost identical for every second sublevel, which means that drifts on the first sublevel are positioned right on top of drifts on the third sublevel, while drifts on the second sublevel are located underneath pillars



FIGURE 1.23 Twin boom rig for fan drilling, with operator's cabin, tube handling, and drill automatics, Kiruna, Sweden

between the drifts on sublevels 1 and 2. A section through the sublevel area will show that the drifts are spread across the ore body in a regular pattern both vertically and horizontally. A diamond-shaped area can be traced above one drift and indicates the volume of ore to be recovered from each drift.

The ore section above the drift is drilled in a fan-shaped pattern with longhole drills (Figure 1.23). Drilling can be done independently of other procedures, often well ahead of charging. Thus, drilling, charging, and blasting longholes can be timed to suit the mine's production schedules. Blasting on each sublevel starts at the hanging wall and mining retreats toward the foot-wall. The cave line should follow an approximately straight front, and hence adjacent drifts should be mined at a similar pace. A section through the cave shows the upper sublevels one step ahead of the sublevels underneath.

Blasting the longhole fan breaks the ore in the slice. Most of the blasted ore remains in place while some falls down into the drift opening. Mucking out with LHDs creates a cave pattern of ore and waste from above. Loading continues until the operator decides there is too much dilution, stops mucking, and moves to another heading. With the heading vacated, the charging team moves into the heading and charges and fires the next ring of longholes.

Ore handling involves mucking out the blasted material at the front, transporting it on the sublevels, and dumping the ore into ore passes. These are ideal conditions for LHDs as they can be kept in continuous operation. When one face is mucked clean, the LHD is moved to a nearby drift heading and mucking continues. Sublevels are designed with tramming distances matched to particular sizes of LHDs.

Dilution and ore losses are drawbacks for sublevel caving. Extensive scientific investigations have been made to determine the flow of ore in a cave and to identify means of reducing ore losses and minimizing dilution. Dilution varies between 15% and 40%, and ore losses can be from 15% to 25%, depending on local conditions. Dilution is of less influence for ore bodies with diffuse boundaries where the host rock contains low-grade minerals or for magnetite ores, which are upgraded by simple magnetic separators. Sulfides, in contrast, must be refined by costly flotation processes.

Sublevel caving is repetitive both in layout and working procedures. Development drifting, production drilling, charging, blasting, and mucking are all carried out separately. Work takes place at different levels, allowing each procedure to be carried out continuously without disturbing the others. There is always a place for the machine to work.

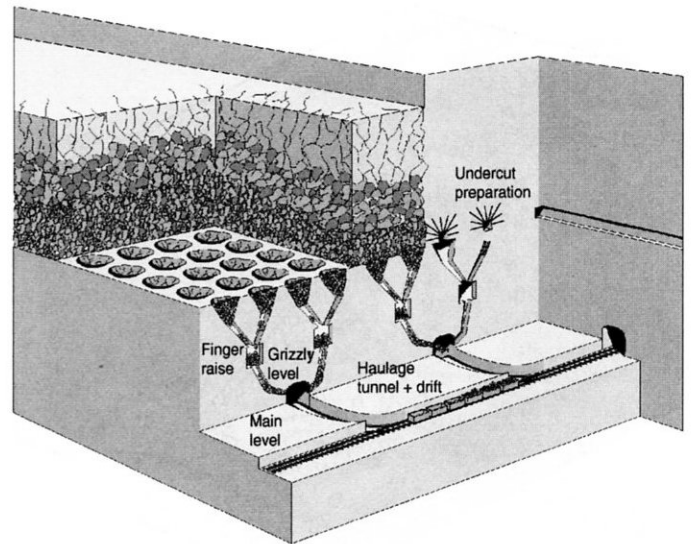

FIGURE 1.24 Block caving with finger raises, grizzly treatment and chute loading

1.3.11 Block Caving

Block caving is a technique in which gravity is used in conjunction with internal rock stresses to fracture and break the rock mass into pieces that can be handled by miners. "Block" refers to the mining layout in which the ore body is divided into large sections of several thousand square meters. Caving of the rock mass is induced by undercutting a block. The rock slice directly beneath the block is fractured by blasting, which destroys its ability to support the overlaying rock. Gravity forces on the order of millions of tons act on the block, causing the fractures to spread until the whole block is affected. Continued pressure breaks the rock into smaller pieces that pass through drawpoints where the ore is handled by LHDs.

Block caving is a large-scale production technique applicable to low-grade, massive ore bodies with the following characteristics:

- Large vertical and horizontal dimensions,
- A rock mass that will break into pieces of manageable size, and
- A surface that is allowed to subside.

These rather unique conditions limit block caving to particular types of mineral deposits. Looking at worldwide practices, one finds block caving used for extracting iron ore, low-grade copper, molybdenum deposits, and diamond-bearing kimberlite pipes. The large tonnage produced by each individual mine makes block-caving mines the real heavyweights when compared to most other mines.

The development of block caving when conventional gravity flow is applied (Figure 1.24) involves

- An undercut where the rock mass underneath the block is fractured by longhole blasting,
- Drawbells beneath the undercut that gather the rock into finger raises,
- Finger raises that collect rock from drawbells to the grizzlies,
- A grizzly level where oversized blocks are caught and broken up,

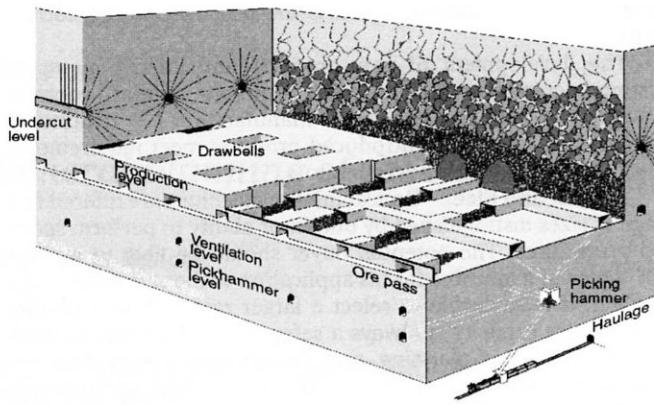

FIGURE 1.25 Block caving LHD loaders and pick-hammer control, El Teniente, Chile

- A lower set of finger raises that channel ore from grizzlies to chutes for train loading. The finger raises are arranged like branches of a tree, gathering ore from a large area at the undercut level and further channeling material to chutes at the haulage level.
- A lowermost level where ore is prepared for train haulage and chute loading.

Openings underneath the block are subject to high internal stresses. Drifts and other openings in a block-caving mine are excavated with minimal cross sections. Heavy concrete liners and many rock bolts are necessary to secure the integrity of mine drifts and drawpoint openings.

After completion of the undercut, the rock mass above begins to fracture. The blocks are gathered by drawbells and crates and funneled down through finger raises. The intention is to maintain a steady flow from each block. Miners keep records of the volume extracted from individual drawpoints. Theoretically, no drilling and blasting are required for ore production. In practice, it is often necessary to assist rock mass fracturing by long-hole drilling and blasting in widely spaced patterns. Boulders that must be broken by drilling and blasting frequently interrupt the flow. Large blocks cause hang-ups in the cave that are difficult and dangerous to tackle.

Originally, block-caving techniques relied 100% on gravity flow to deliver ore from the cave into rail cars. The ore was funneled through a system of finger raises and ore passes, ending at trough chutes at the main haulage level. As chute loading requires controlled fragmentation, the rock had to pass through a grizzly before it entered the ore pass. The grizzly-man with a sledgehammer used to be a bottleneck in old-style block-caving mines. Now it is common to use hydraulic hammers for breaking the boulders.

Today, block-caving mines have adapted trackless mining in which LHDs are used to handle the cave in the drawpoints (Figures 1.25 and 1.26). As a consequence, ventilation must be added to development preparations to clear the production level of diesel exhaust. The LHDs are able to handle large rocks while oversized boulders are blasted in the drawpoints.

Block caving is an economical and efficient mass-mining method when rock conditions are favorable. The amount of drilling and blasting required for ore production is minimal while the development volume is immense. The behavior of the rock mass and conditions for caving are difficult to predict when a block-caving mine is planned. The extensive development

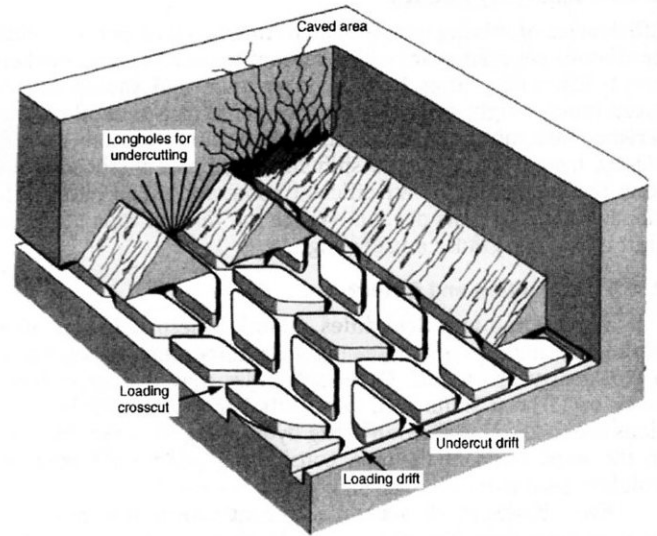

FIGURE 1.26 Block caving with one-level development, longhole undercutting and drawpoint loading

required and time lag before production starts are also factors to consider when block caving is being compared to other methods.

1.4 MECHANIZATION AND EFFICIENCY

1.4.1 Preparing for the Future

The mining industry exists in a competitive environment. The only way to survive in the long term is to ensure that each ton of ore mined leaves a profit after all cost factors are deducted. All of us face a climate of escalating labor costs and tougher environmental rules that increase the burden on production costs. Development of new equipment and improved efficiency help us compensate for these increasing cost factors.

1.4.2 Mechanization—Automation—Robotics

Labor represents a major share of the production costs in underground mines. Replacing labor with powerful machines is a natural way to counteract escalating costs. Mechanization has proven itself by a steady increase in production in underground mines over the last few decades. More duties are being taken over by machines, more powerful machines increase output, and more sensitive controls are able to handle dangerous and complex procedures to produce a higher quality product.

Elaborate machines in the hands of skilled operators turn mine production into an efficient industrial process. Any mine will have the potential to introduce new equipment and improve existing standards by exploiting the potential of modern technology.

1.4.3 Quality and Grade Control

Economic mining is a matter not only of production efficiency, but also the quality or grade of the run-of-mine product. Thus, the degree of selectivity achieved by equipment and methods becomes a prime consideration. Mechanized cut-and-fill mining is highly selective. The cut-and-fill method is adaptable to variations in ore body boundaries and rock conditions, which makes it interesting for mine prospects and rehabilitation projects. Cement-consolidated backfill has improved recovery during open stoping so that this method is comparable with cut-and-fill mining.

1.4.4 Efficiency Ratings

Efficiencies of mining operations are rated in tons per man-shift or kilotons per man-year (with reference to underground workers only). Efficiency varies from mine to mine and should not be given much weight except when considered as a general characteristic. Each mining method provides certain conditions for efficiency, from 1 ton per man shift for a complex method to 100 tons per man-shift for an efficient room-and-pillar mine. Efficiency relates to costs per ton. Where the ratio of tons per man-shift is low, ore grades must be high.

1.4.5 Utilization and Output

Work Time and Schedules. Work time in mines is often based on schedules of 8 hours per shift, three shifts a day, 7 days a week all year around. Other schedules may include a 6-day week or 11-hour shifts with two shifts per day. Evidently ambitions are to keep production going by utilizing the available time in the most efficient manner, considering public and religious holidays.

Even if the work schedule is continuous, few machines operate more than 70% of the time. Machines that can be kept in operation much of the time are those directly involved with production—longhole drill rigs, LHDs, and mine trucks. For other demands, such as development drifting and rock bolting, 30% use would be considered normal. The machine itself is a tool for doing things in a practical way that minimizes manual efforts.

Multipoint Attack. The mining method influences conditions for use of mechanized equipment. Drill-blast rock excavation involves a cycle featuring frequent changes of techniques and machinery. Where several attack points lie within a reasonable distance of one another, machines can be kept busy shuttling from one workplace to the next. A drill rig, charging truck loader, and other machines should be scheduled to minimize delays while they are changing places.

Work Specialization. Carrying out the continuity and volume of a specific procedure without interruption is important. Sublevel stoping, VCR mining, and sublevel caving are methods in which drilling, charging, blasting, and mucking out are independent procedures. The longhole drill rig keeps hammering in the same drift for long periods of time, promoting output from an elaborate and capital-intensive machine. As longhole drilling is independent of mucking out, blastholes can be drilled and maintained until the production schedule calls for more tonnage.

1.4.6 The Machine—A Versatile Tool

Selecting Machines. Selecting a machine for a specific purpose is a complex procedure. The application is rarely straightforward, but includes special requirements and restrictions. The machine itself is a complex device with capabilities that are difficult to explain in specification sheets. A dialogue between a mine's technical staff and a manufacturer's representative

prevents misunderstandings and is the best way to the correct choice.

The development of new products and improvements to existing equipment is enhanced through regular contacts between the end-user and the manufacturer. A continuing dialogue ascertains that introduced products meet requirements from both management and operators.

Output and Size. Typical mining machines are offered in a range of sizes distinguished by output or ability to perform specified procedures. The potential buyer should be able to make a first choice of a machine for his application without too much of a problem. It is advisable to select a larger rather than a smaller model. Extra capacity is always a safety margin, adding to flexibility in production planning, and a heavy-duty design increases resistance to wear and tear in a tough underground environment.

Capability. Qualifications of a machine are documented in the technical specification pages. Here, the important data, such as engine power, weight, length, width, etc., should be found. The specification sheet should be studied carefully before a decision is made on a new machine. The machine must meet expectations, in terms of both performance and capability, and it must fit inside the mine's drift openings.

Options and Extras. Specifications come with a list of options and special features that can be added to a basic machine at additional cost. Each option should be checked and analyzed with regard to selecting the basic machine. Some options will be necessary for the proper function of the basic unit, while others may seem to be fancy gadgets without real justification. As the basic machine represents the major share of the capital to be invested, the options may add valuable qualities to the basic unit at marginal extra cost. The value of option-services integrated into the basic unit should be assessed by the end-user.

1.5 SUMMARY

In the preceding sections, the author has tried to present conventional underground mining methods as clearly as possible. Naturally, there are additional considerations that cannot be included within the scope of this text.

Some readers may miss the inclusion of more detailed figures in the text. However, the variations in ore deposits are so great and the state of mining technology so dynamic that being too specific could mislead the reader. Every ore body is unique. The successful application of a mining method requires more than textbook knowledge; it also requires practical reasoning with a creative mind that is open to new impressions. The application of a mining method is a distinct challenge to any mining engineer.

The author wishes to express his gratitude to Atlas Copco MCT AB for permission to use the material included herein and for assistance in preparing the illustrations.